

**Rechteckführung
(kompatibel zu Z46)**

**Square Guide
(Compatible with Z46)**

S1211/...

Teil ①

Mat.: Einsatzstahl, **mit Schmiernuten**
Härte: 56 HRC, gehärtet und geschliffen

Part ①

Mat.: Case-hardened steel, **with lubrication grooves**
Hardness: 56 HRC, hardened and ground

Teil ②

Mat.: Einsatzstahl, **DLC-beschichtet**
Härte: 70 HRC, gehärtet und geschliffen

Part ②

Mat.: Case-hardened steel, **DLC-coated**
Hardness: 70 HRC, hardened and ground

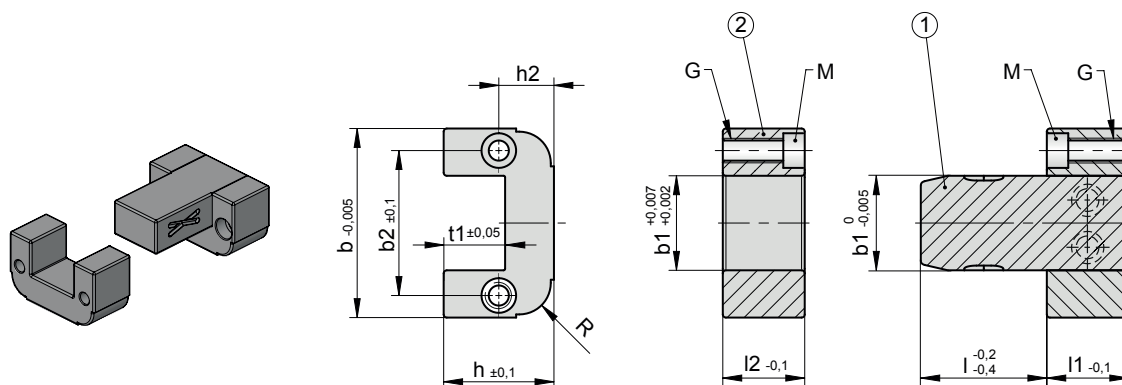

t1	b	b2	h	h2	l1 = l2	R	M	G	b1	l1	l	Best. Nr. / Order No.
12	45	30	22	11	20	8	M6	M8	16	20	20	S1211/16x20x 20
											40	S1211/16x20x 40
20	60	46	35	17,5	26	10	M6	M8	30	26	40	S1211/30x26x 40
											63	S1211/30x26x 63
											32	S1211/48x36x 32
26	100	74	46	23	36	12,5	M10	M12	48	36	50	S1211/48x36x 50
											63	S1211/48x36x 63
											80	S1211/48x36x 80
											50	S1211/77x56x 50
36	150	114	60	30	56	16	M12	M16	77	56	71	S1211/77x56x 71
											100	S1211/77x56x 100

Einbauhinweise:

Mounting instructions:

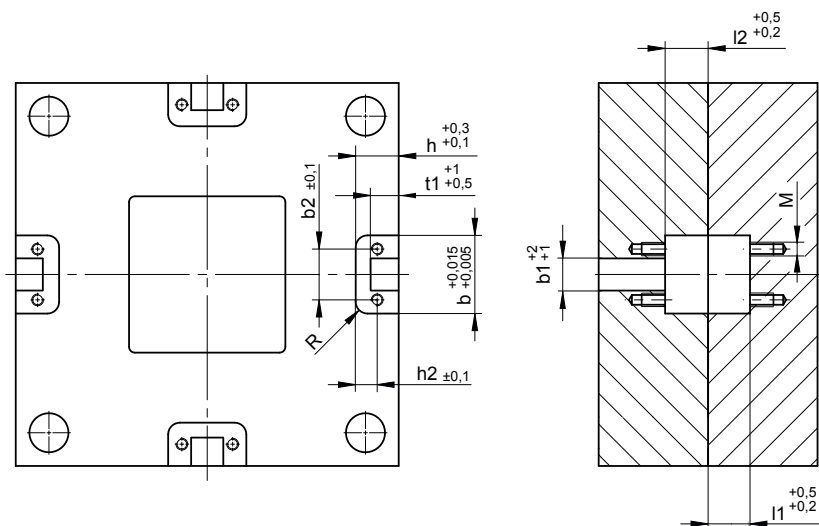

Auf Wunsch auch ohne Schmiernuten.

On request delivered without lubrication grooves.